

Thank you for your purchase!

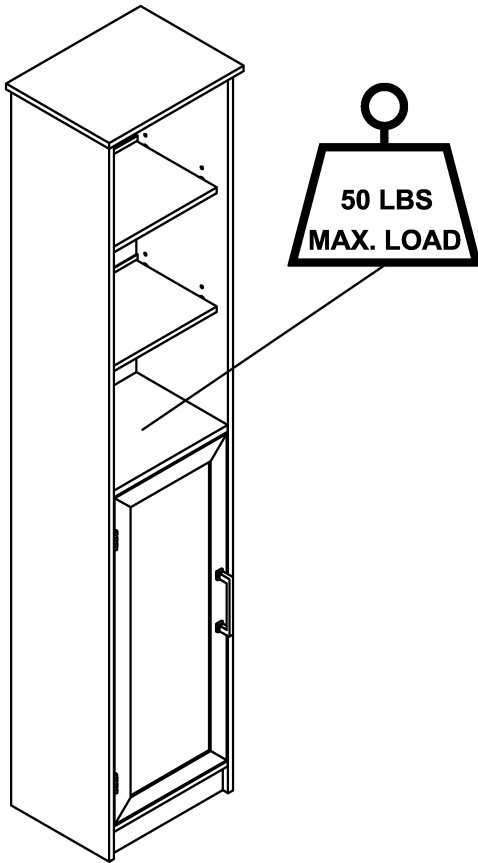

FLOORSTANDING TALL LINEN CABINET

ASSEMBLY INSTRUCTIONS

Before You Begin: Phillips screwdriver is required for assembly (Not Included).

Please identify all component parts and hardware pieces required before you begin. Carefully remove all of the components from the packaging and set aside for assembly. Assemble on a soft surface to prevent scratching during assembly.

Caution:

Tighten all components securely before use. Failure to do so may result in personal injury. DO NOT use any sharp objects to open plastic wrapped components as damage to product or components may result.

Warning:

CHOKING HAZARD - Small Parts. Adult Assembly Required.

DO NOT ALLOW CHILDREN TO CLIMB ON FURNITURE

Serious or fatal injuries can occur from furniture tipping over. You must install Tipping Restraint Hardware (where included) to help prevent the unit from tipping and causing accidental injury, instability, death or damage. The tipping restraint is intended only as a safety measure, it is not a substitute for proper adult supervision.

To help prevent furniture from tipping over it must be permanently attached to the wall. Anti-Tip Safety Wall Straps suitable for the unit weight and wall materials (if not included) should be purchased and installed.

Customer Service Email: Customerexperience@theubiquegroup.com | Phone: 866-552-2810

889142955689 / 889142955672



Congratulations!

You just purchased a piece of happiness. At Ubique Group, we believe you can transform your spaces into the most inspired places with furnishings that are the perfect combination of form, function and style. As original innovators of online furniture retail, we offer the best selection of popular, contemporary styles at cool, comfortable prices. And, with decades of proven shipping and packaging expertise, our Extended Quality Checklist ensures a rewarding, hassle-free experience time and time again. It's just what you need to bring your vision to life.

Thank you & Enjoy!!

your friends at Ubique Group



LIKE IT!

*Share it on social
& Tell a friend!
#Spaces2Places*



LOVE IT!

*Write an online
product review
where purchased*



NOT SURE?

*Let us help!
Contact our
customer support.*

Have a question, concern or simply need a hand? Your satisfaction is our top priority. Contact us at 866-552-2810 or customerexperience@theubiquegroup.com. We're here to help!

Browse Our Branded Collections

There's something for everyone inside our family of brands.

FLASH
FURNITURE®

MERRICK | LANE

Taylor & Logan

Emma+Oliver®

MASADA
RUGS

HBCY
CREATIONS

BlackArc®



Visit www.theubiquegroup.com/brands or scan this code.



We pride ourselves on providing an excellent customer experience starting right here with your package and instructions. Everything you need should be right where you need it, so you can get to enjoying your new item ASAP. But despite our best efforts, sometimes "slips happen." If you need any support, from replacement parts to recommendations, please reach out to our wonderful customer support team at 866-552-2810 or customerexperience@theubiquegroup.com. We're here to help!

EVERY UBIQUE GROUP PRODUCT



Quality &
Durability Tested



Packaged
with Care



Shipped from
our U.S. Facility

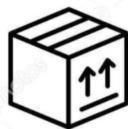

Designed
for Easy
Assembly







Ethically
Sourced

Please visit <https://www.theubiquegroup.com/warranty> for complete warranty information.

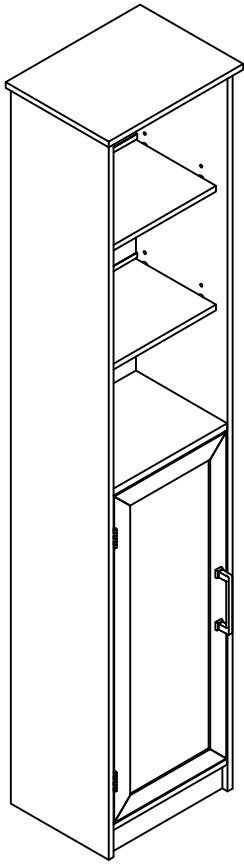

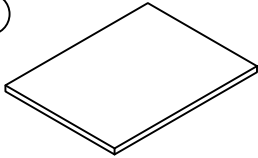
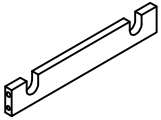
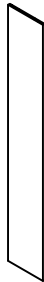

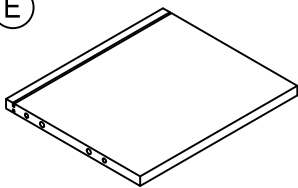
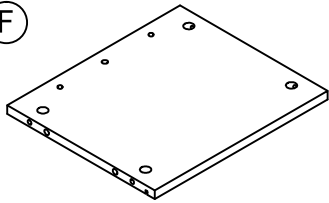
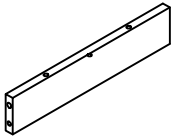
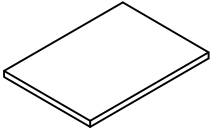
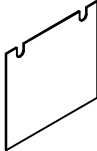
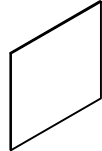
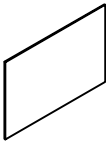

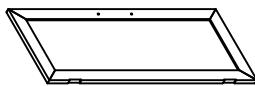
Read this manual before using this product. Failure to follow the instructions and safety precautions in this manual can result in serious injury or death. Keep this manual in a safe location for future reference.

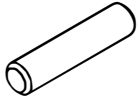

PARTS LIST

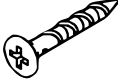

<p>(A)</p>  <p>TOP 1PC</p>	<p>(B)</p>  <p>UPPER REAR BRACE 1PC</p>
<p>(C)</p>  <p>LEFT SIDE 1PC</p>	<p>(D)</p>  <p>RIGHT SIDE 1PC</p>
<p>(E)</p>  <p>FIXED SHELF 1PC</p>	<p>(F)</p>  <p>BOTTOM 1PC</p>
<p>(G)</p>  <p>BOTTOM RAIL 1PC</p>	<p>(H)</p>  <p>ADJUSTABLE SHELF 3PCS</p>
<p>(I)</p>  <p>UPPER BACK PANEL 1PC</p>	<p>(J)</p>  <p>MIDDLE BACK PANEL 1PCS</p>
<p>(K)</p>  <p>LOWER BACK PANEL 1PCS</p>	<p>(L)</p>  <p>H CLIP 4PCS</p>
<p>(M)</p>  <p>DOOR 1PC</p>	

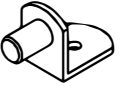
HARDWARE LIST

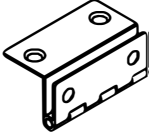
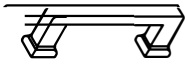
ITEM	DESCRIPTION	QTY
①	Ø8*30mm WOOD DOWELS 	17 pcs
②	Ø6*34mm CAMLOCK 	18 pcs
③	Ø15*9mm CAMLOCK 	18 pcs
④	#4*40mm SCREW 	2 pcs
⑤	#4*15mm SCREW 	2 pcs
⑥	#3.5*15mm SCREW 	10 pcs
⑦	20x18x14mm SHELF PIN 	12 pcs

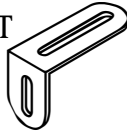
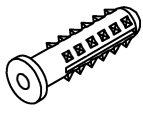
ITEM	DESCRIPTION	QTY
⑧	#3.5*12 SCREW 	12 pcs
⑨	HINGE 	2 pcs
⑩	HANDLE 	1 pc
⑪	5/32"*22mm BOLT 	2 pcs
⑫	METAL BRACKET 	2 pcs
⑬	WALL ANCHOR 	2 pcs

INSTALLATION

STEP 1

NOTE: Do not completely tighten screws on part 12.

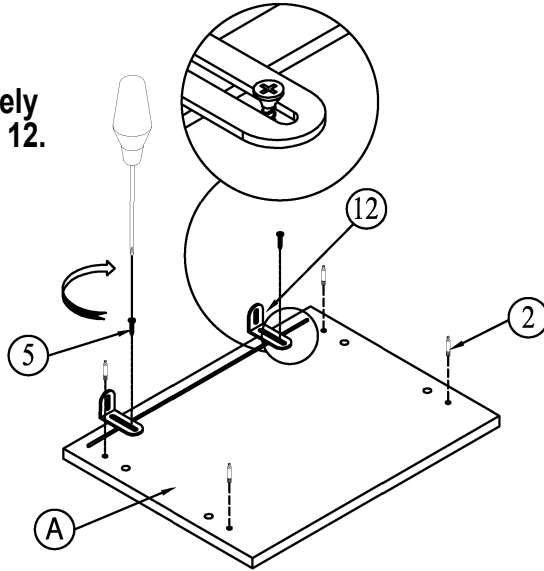

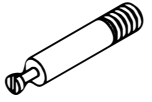
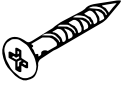
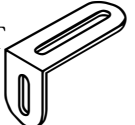
- (2) Ø6*34mm CAMLOCK 4pcs 
- (5) #4*15mm SCREW 2pcs 
- (12) METAL BRACKET 2pcs 

STEP 2

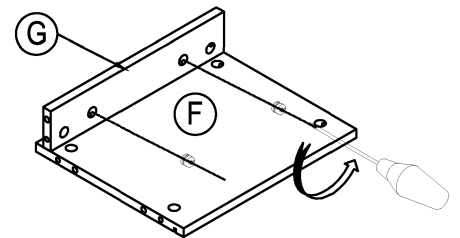
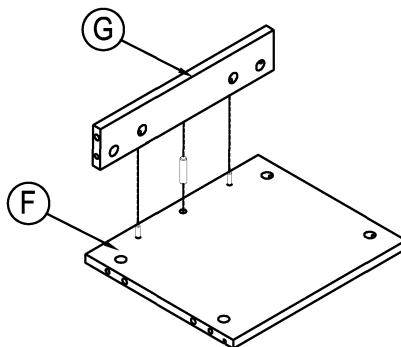
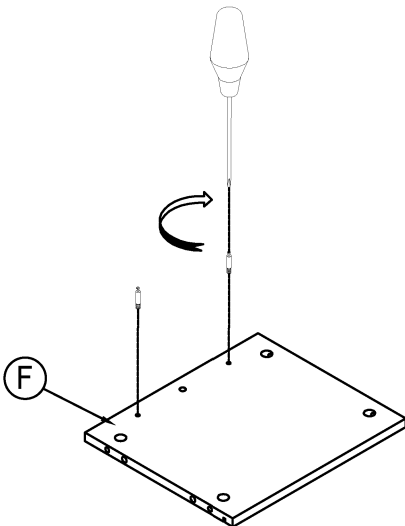

- (2) Ø6*34mm CAMLOCK 2pcs 

- (1) Ø8*30mm WOOD DOWELS 1pc 

- (3) Ø15*9mm CAMLOCK 2pcs 

STEP 3

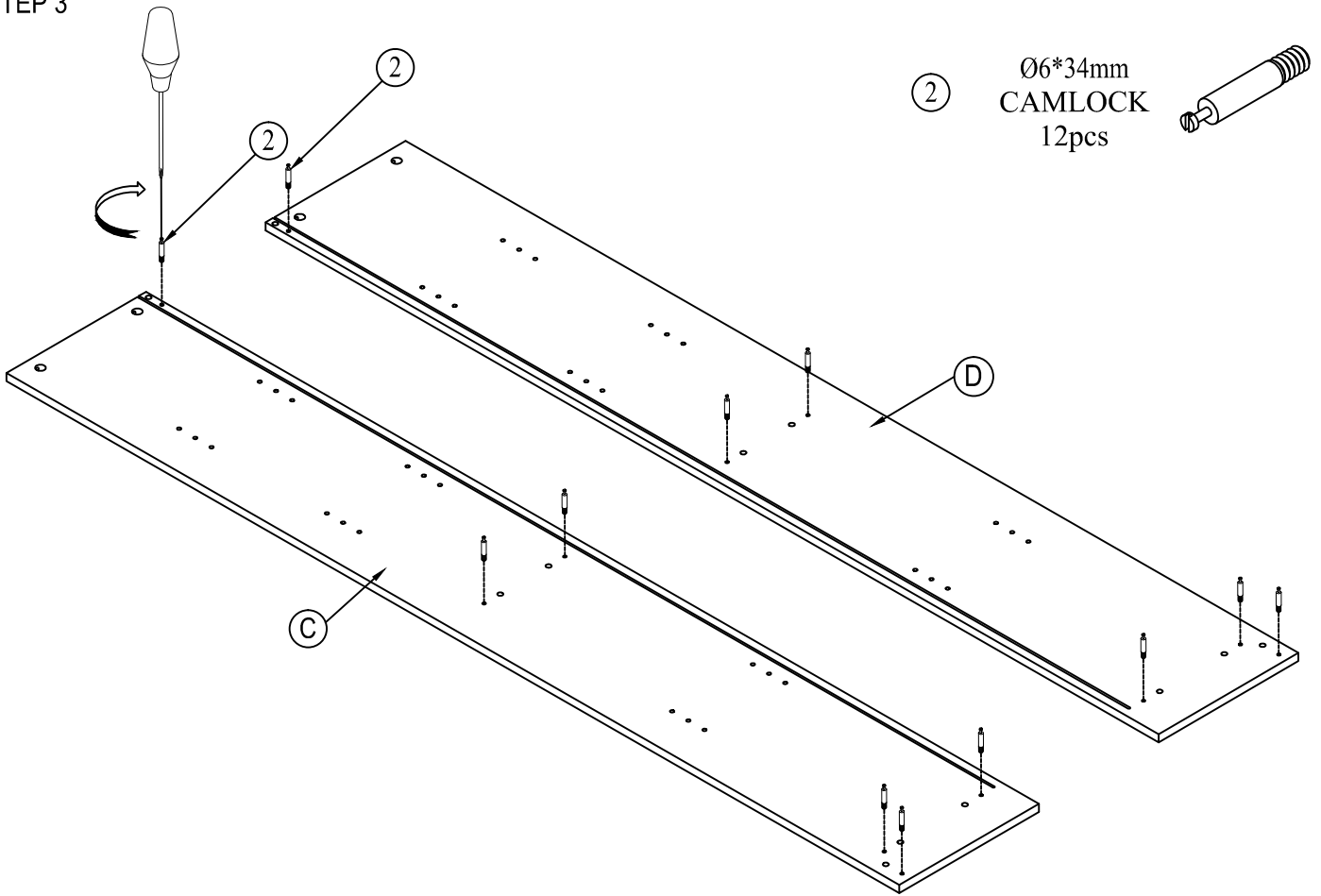

STEP 4

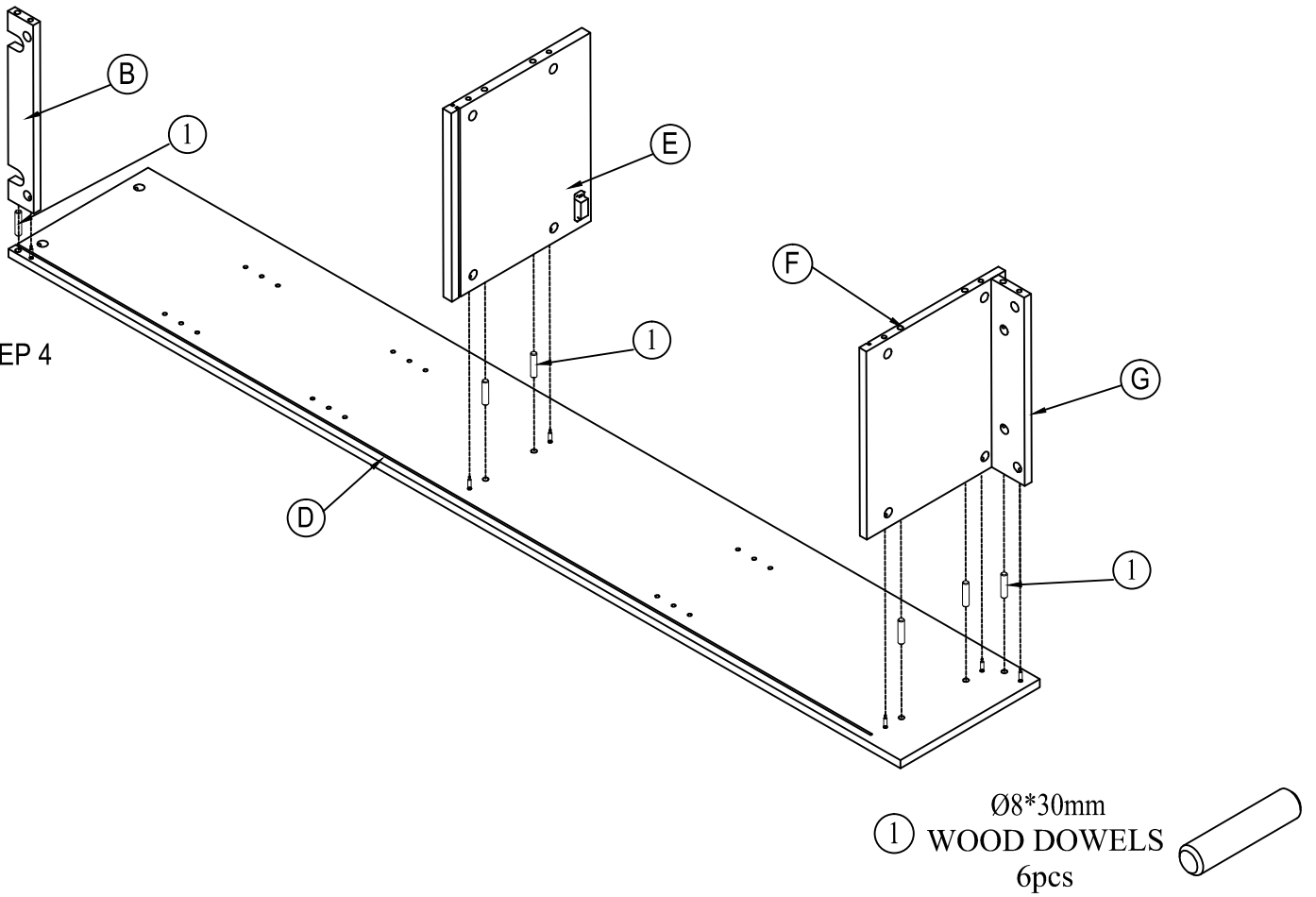

STEP 7

① Ø8*30mm
WOOD DOWELS
6pcs

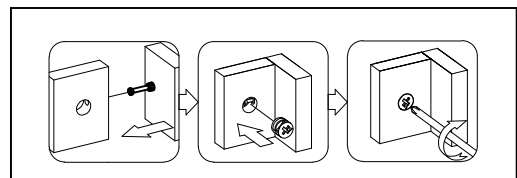
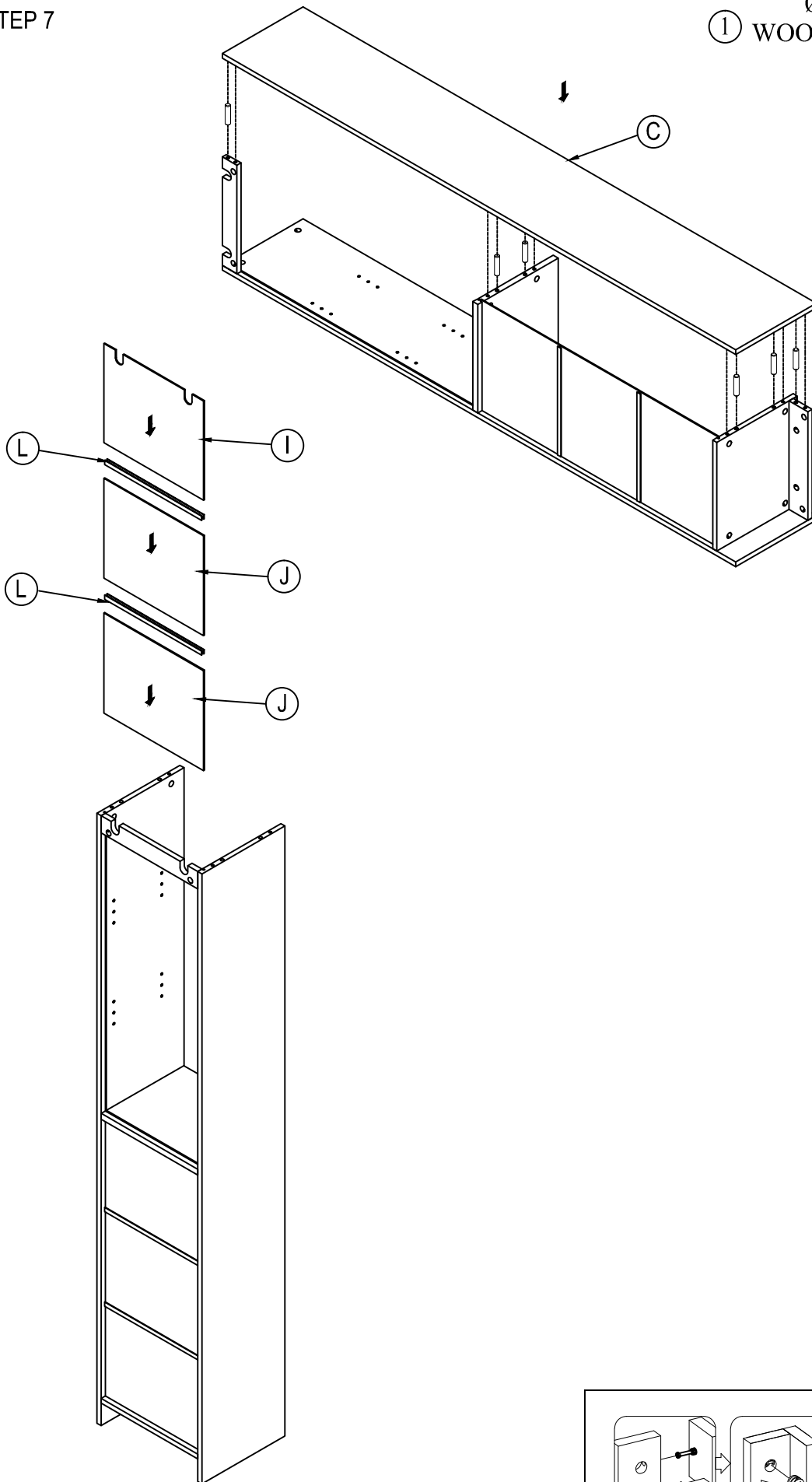
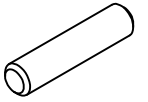

STEP 8

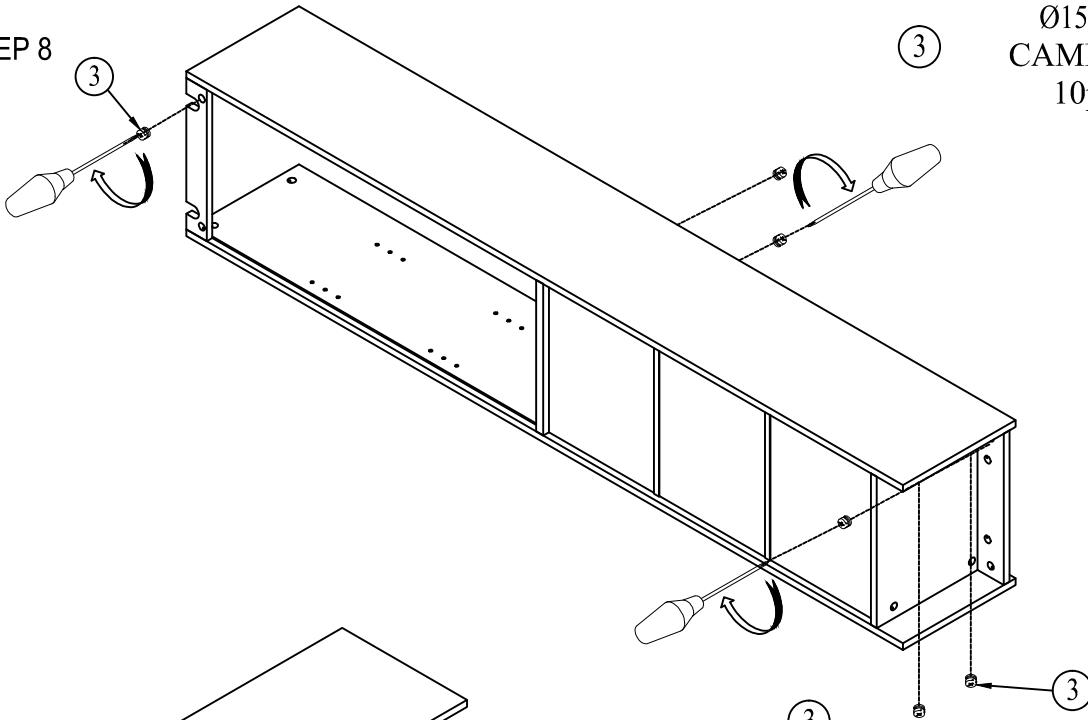

Ø15*9mm
CAMLOCK
10pcs



STEP 9

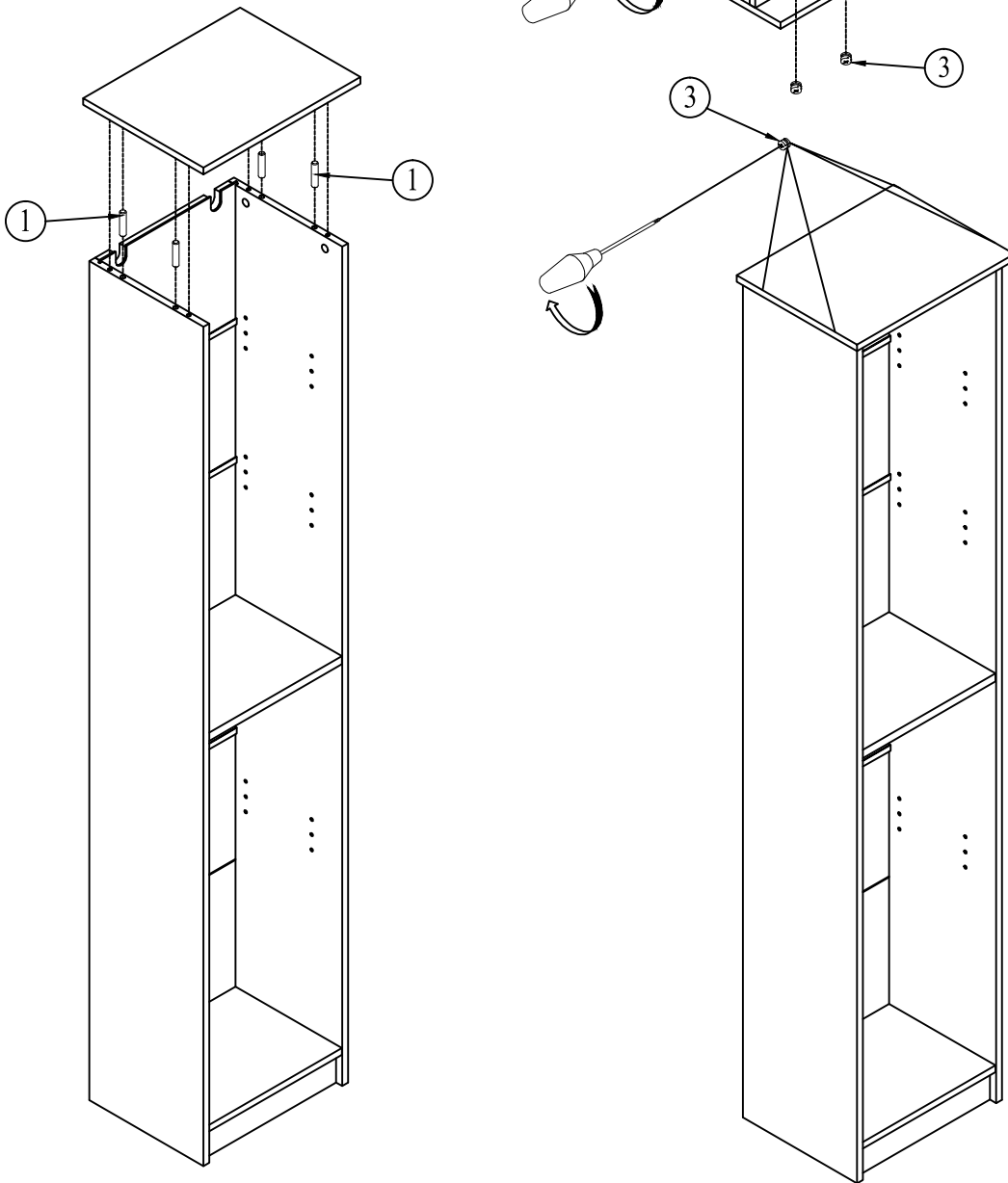

① Ø8*30mm
WOOD DOWELS
4pcs

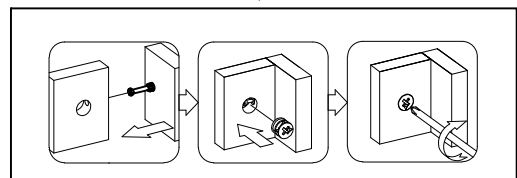
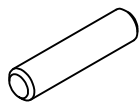

STEP 10

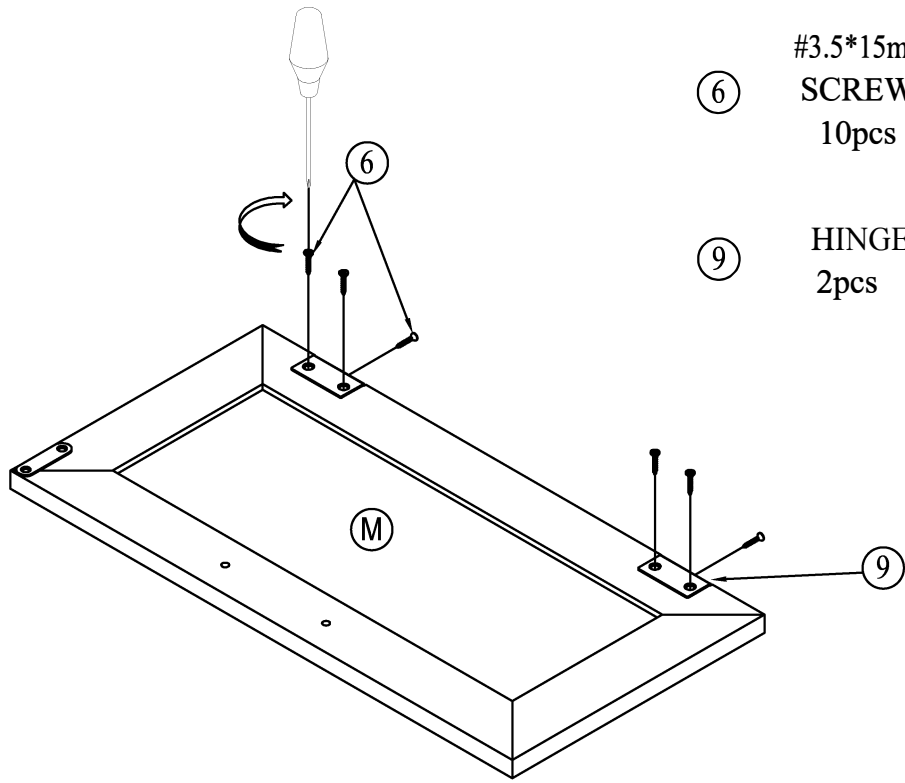

⑥ #3.5*15mm
SCREW
10pcs



⑨ HINGE
2pcs

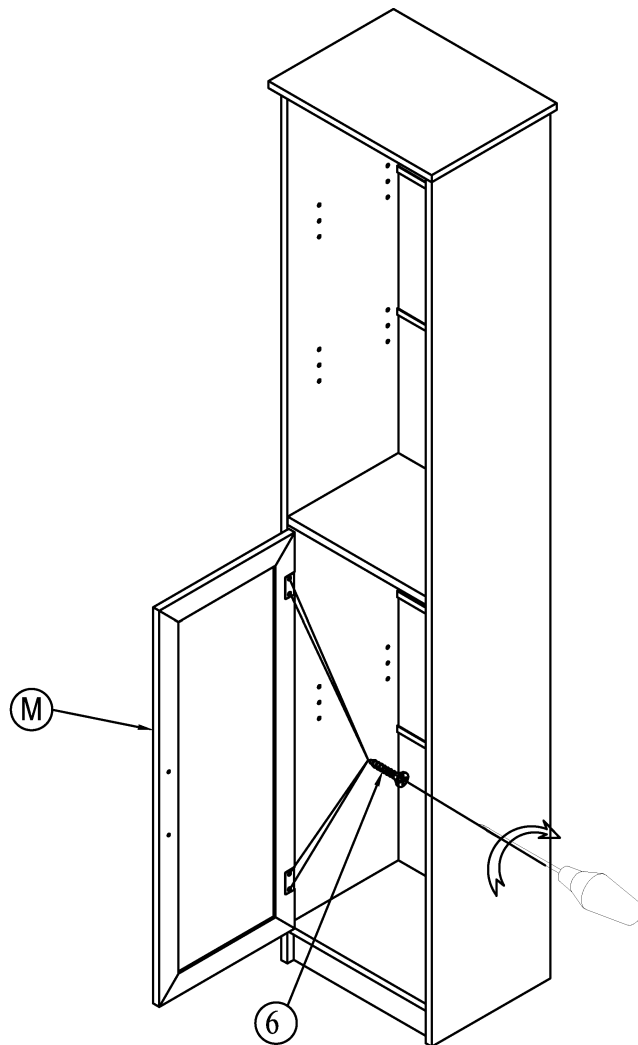
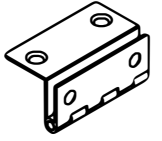

STEP 11

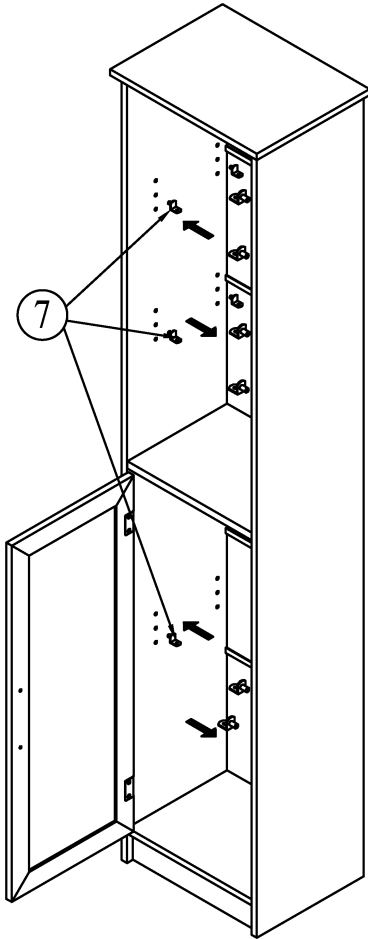

⑦

20x18x14mm
SHELF PIN
12pcs

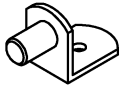

STEP 12

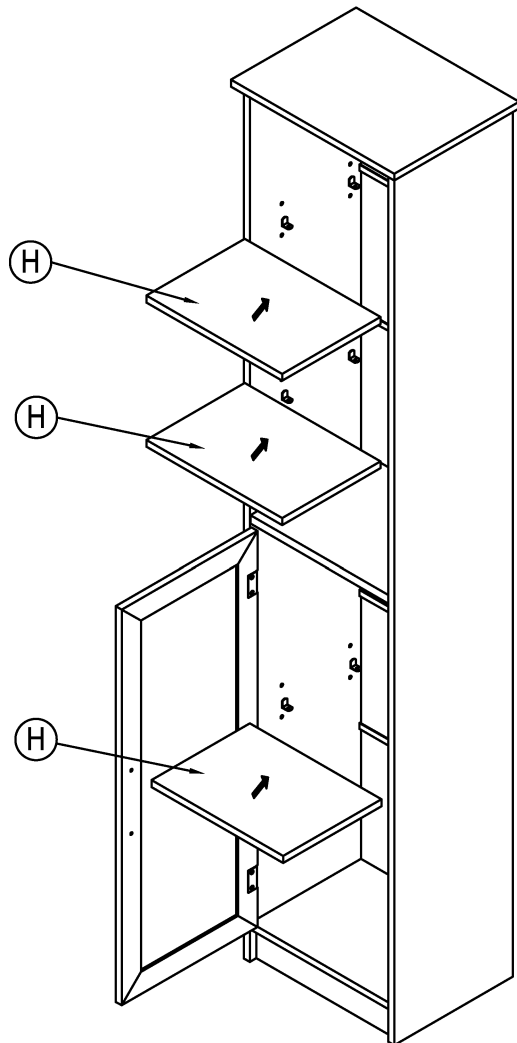

ⓓ

ⓓ

ⓓ

STEP 13

⑧ #3.5*12
SCREW
12pcs

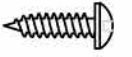

⑩ HANDLE
1pc



⑪ 5/32"*22mm
BOLT
2pcs

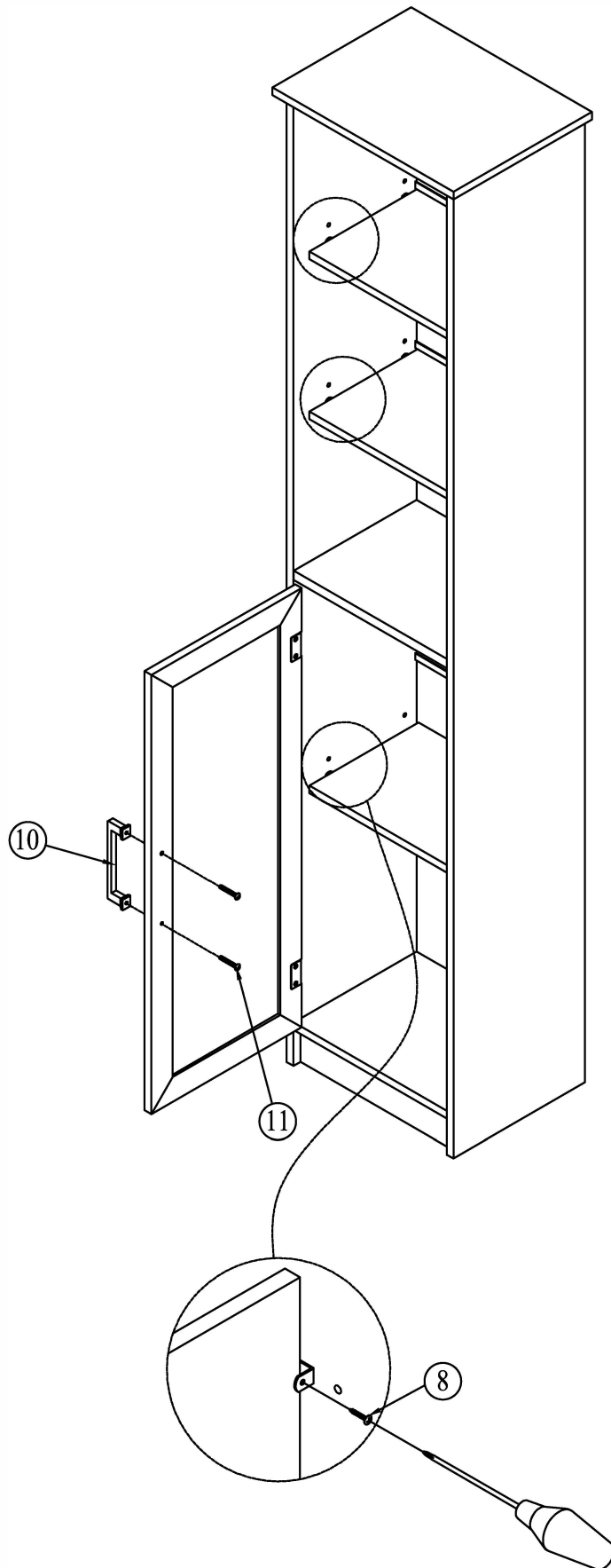

STEP 14

④ #4*40mm
SCREW
2pcs



⑬ WALL ANCHOR
2pcs

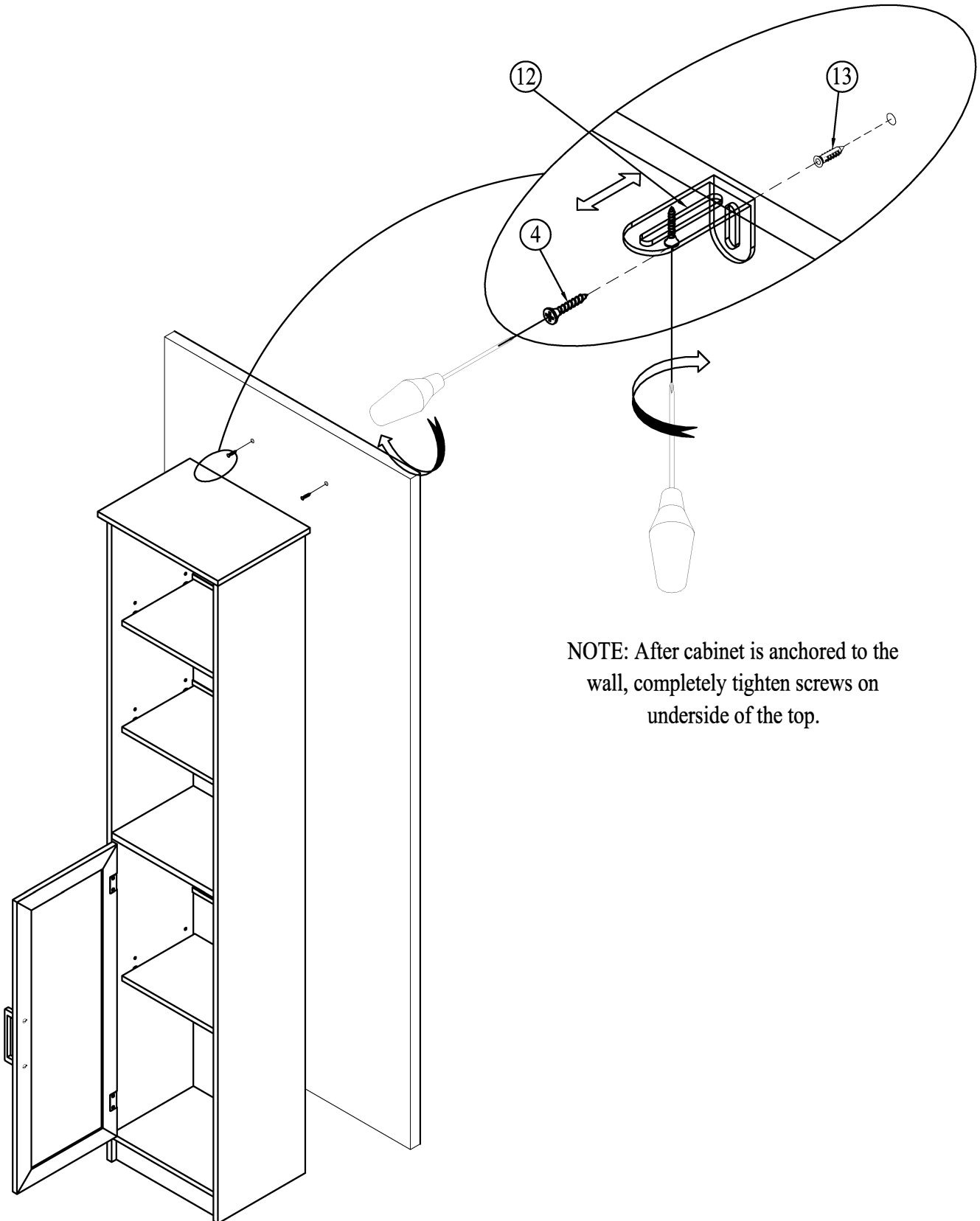

NOTE: After cabinet is anchored to the wall, completely tighten screws on underside of the top.

Quality and Safety Guidelines:

Please follow the static and dynamic weight capacity limits provided on this item. If you are unsure of the weight capacities for this product, email us at customerexperience@theubiquegroup.com or call 866-552-2810.

Please use this item on a stable, level surface only. All legs should contact the flooring surface when in use. Do not use this item if any instability is detected.

Please install and use anti-tipping devices, wall anchors or attach directly to wall with appropriate hardware.

For maintenance instructions and replacement parts, please email us at customerexperience@theubiquegroup.com or call 866-552-2810.

This item is intended as a bathroom cabinet only, do not climb, stand or sit on this item. Do not use this item as a TV stand.

Do not use this product as a clothing storage unit.

Keep fingers away from the hinge line clearance to avoid pinching.

The item is intended to be used indoors.

Please inspect this product regularly to make sure there are no damaged or worn parts. Also inspect to make sure all hardware is tightened correctly and securely. For inspection instructions, please email us at customerexperience@theubiquegroup.com or call 866-552-2810.

If any parts are damaged or worn, please stop using the product. Repair this product with manufacturer supplied parts only.

For product longevity, product safety and product integrity, protect from wet and humid weather or other wet, humid or moist conditions and store indoors in a dry location. For additional storage and usage instructions, please email us at customerexperience@theubiquegroup.com or call 866-552-2810.

Please visit www.theubiquegroup.com for our product warranty details or email us at customerexperience@theubiquegroup.com or call 866-552-2810.